

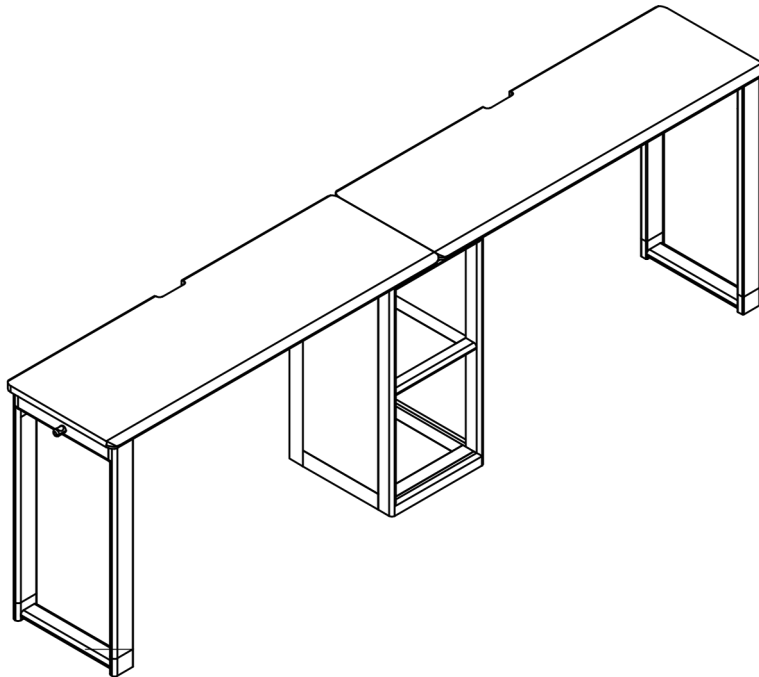

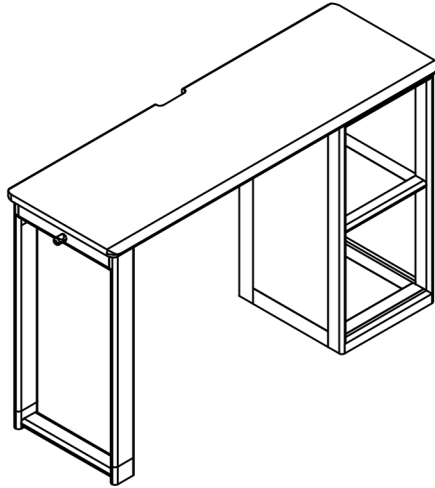



Assembly Instructions

Product Code: Y101X03 / Y101X04



Hardware List

					
A. Allen Key, 5 mm × 1	B. Allen Bolt, M8×30 mm×6	C. Allen Bolt, M8×60 mm×2	D. Spring Washer, Ø8 × 14 × 8	E. Flat Washer, Ø8 × 18 × 8	F. Wooden Knob × 1

Note

Product appearance may vary; however, the assembly method remains the same.

Assembly Option 1

Assemble the unit according to your preferred configuration. Make sure all components are properly aligned with the pre-drilled holes before tightening.

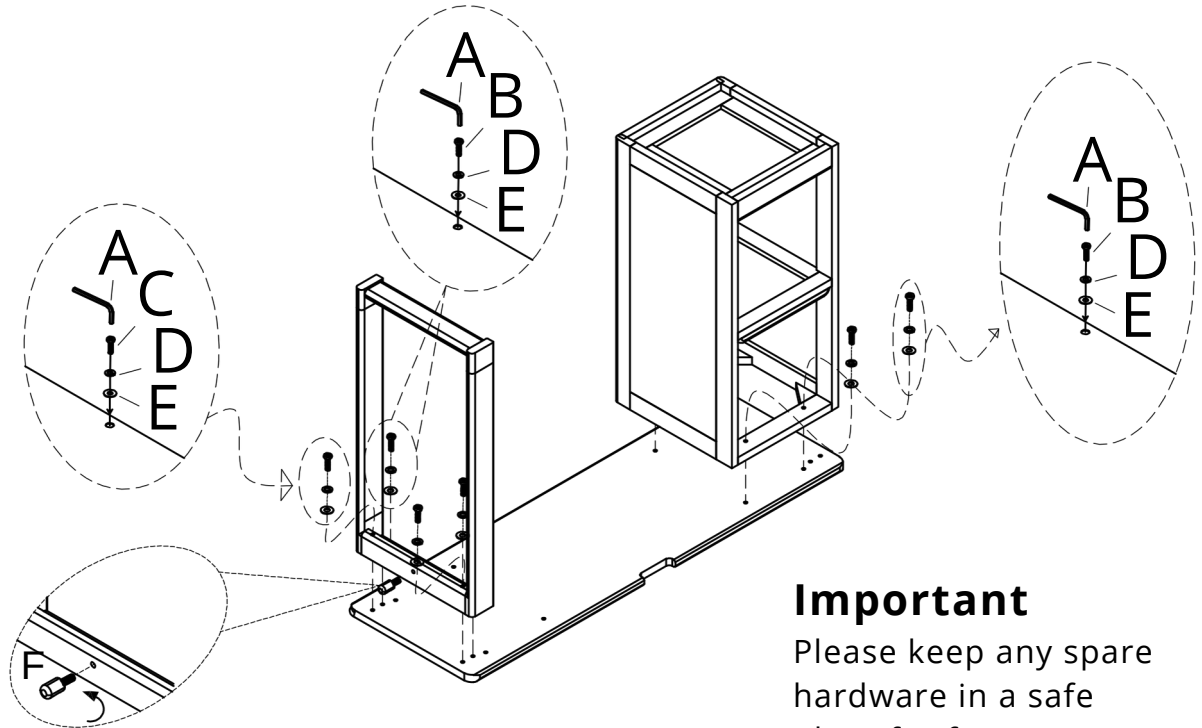

Assembly Option 2

